

FLEXFORM

MADE IN ITALY

MOOD
COLLECTION
2020

Mood Collection

2020

Una collezione di divani, poltrone, sedie e complementi di impronta classica reinterpretata in chiave contemporanea.

Un'idea di decorazione moderna ed attuale che si esprime in una ricerca colta e sofisticata di forme e tessuti, che creano effetti cromatici e accostamenti di texture di grande raffinatezza.

A collection of sofas, armchairs, chairs and accessories with a classic vibe, reinterpreted with a contemporary flair.

A modern, relevant vision of decor that is the product of experimentation with shapes and fabrics that create extremely sophisticated chromatic effects and textural juxtapositions.

Index

WESTON



6

DRAGONFLY 20



30

DROP 20



42

ERMIONE 20



54

LYSANDRE 20



66

DRAGONFLY 20



30

DROP 20



42

ERMIONE 20



54

LYSANDRE 20



66

Weston è un sistema di sedute pensato per chi ama la contemporaneità che evoca reminiscenze della tradizione e il gusto per una decorazione colta e sofisticata.

Il bracciolo del divano Weston è caratterizzato da una linea svasata che conferisce alla silhouette una leggerezza sul piano visivo enfatizzata anche dal disegno degli eleganti piedini in metallo pressofuso che mantengono il divano sollevato da terra.

Il lieve profilo in gros grain che disegna la linea del bracciolo e dello schienale è un raffinato dettaglio "couture" che rivela l'elevato grado di sartorialità che contraddistingue i prodotti della collezione Mood.

Il divano Weston risulta particolarmente affascinante nelle versioni con rivestimenti giocati nei toni del bianco e nero, ma veste con eguale disinvoltura tutti i tessuti e le pelli dell'esclusiva collezione tessile.

Il rivestimento è completamente sfoderabile sia nella versione in tessuto che nella versione in pelle.

A seating system designed for those with a love of the contemporary, Weston is reminiscent of the tradition and taste for discriminating, sophisticated decor.

The flared lines of the Weston armrest lend visual lightness to its silhouette, an impression that is also accentuated by the design of its elegant cast metal feet.

The delicate grosgrain piping that outlines the armrest and backrest is a chic "couture" expression of the finely honed craftsmanship that sets the Mood collection apart.

The Weston sofa upholstery versions that highlight the interplay between black and white are especially eye-catching but the sofa is equally impressive when upholstered in any of the fabrics and leathers from the exclusive materials collection.

Upholstery is completely removable in both the fabric and leather versions.

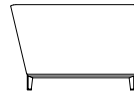

SOFAS
SECTIONAL SOFAS
OTTOMANS







12





16



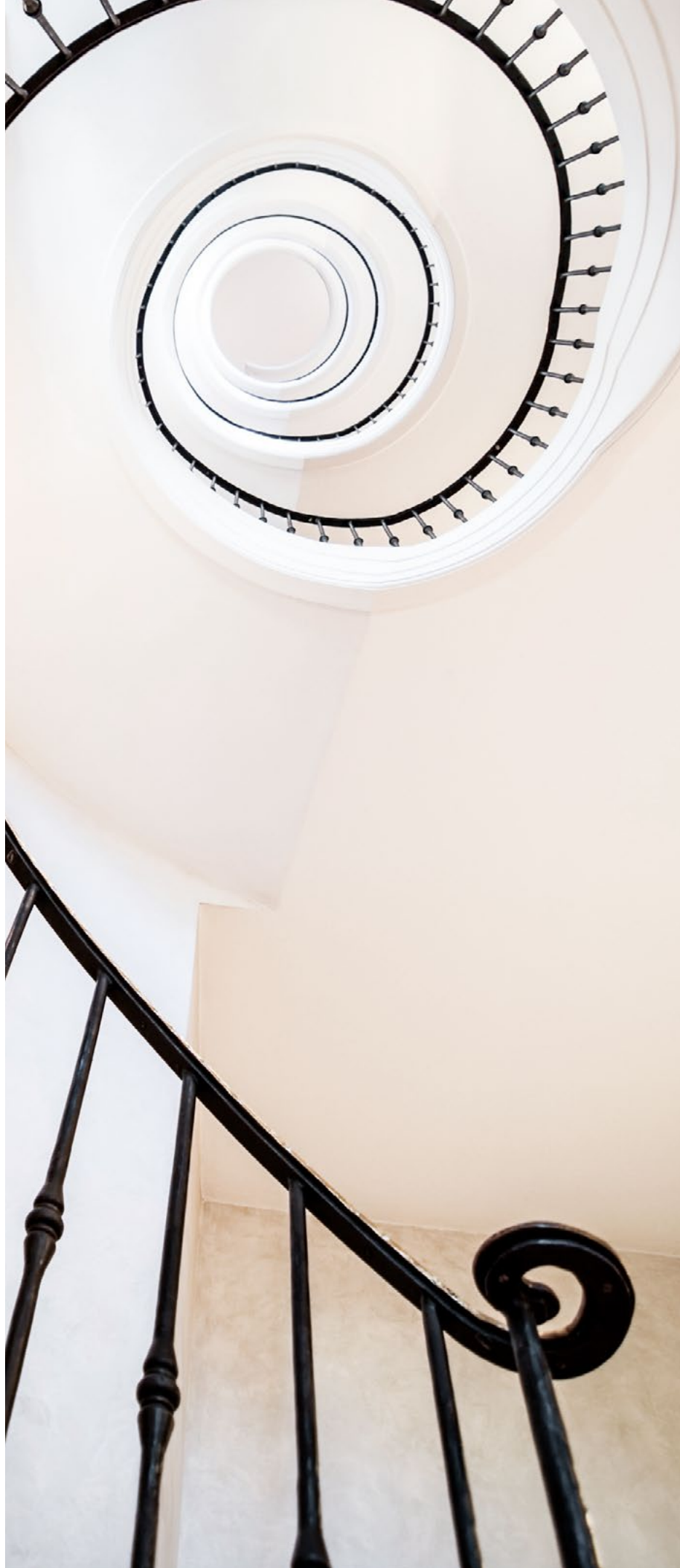





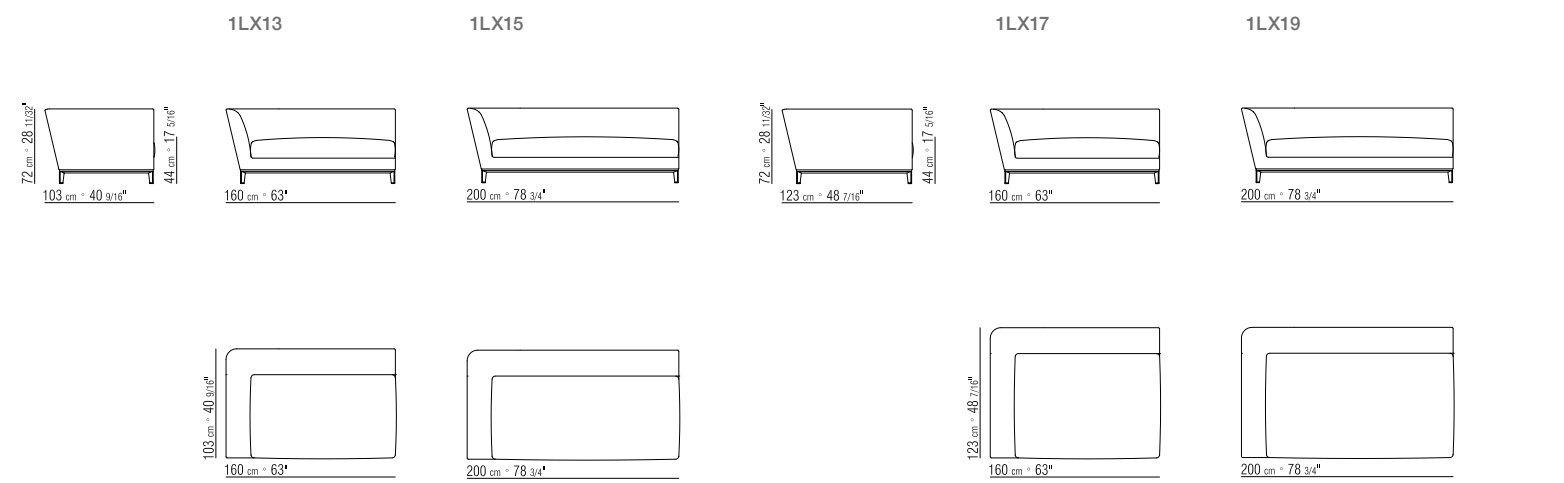
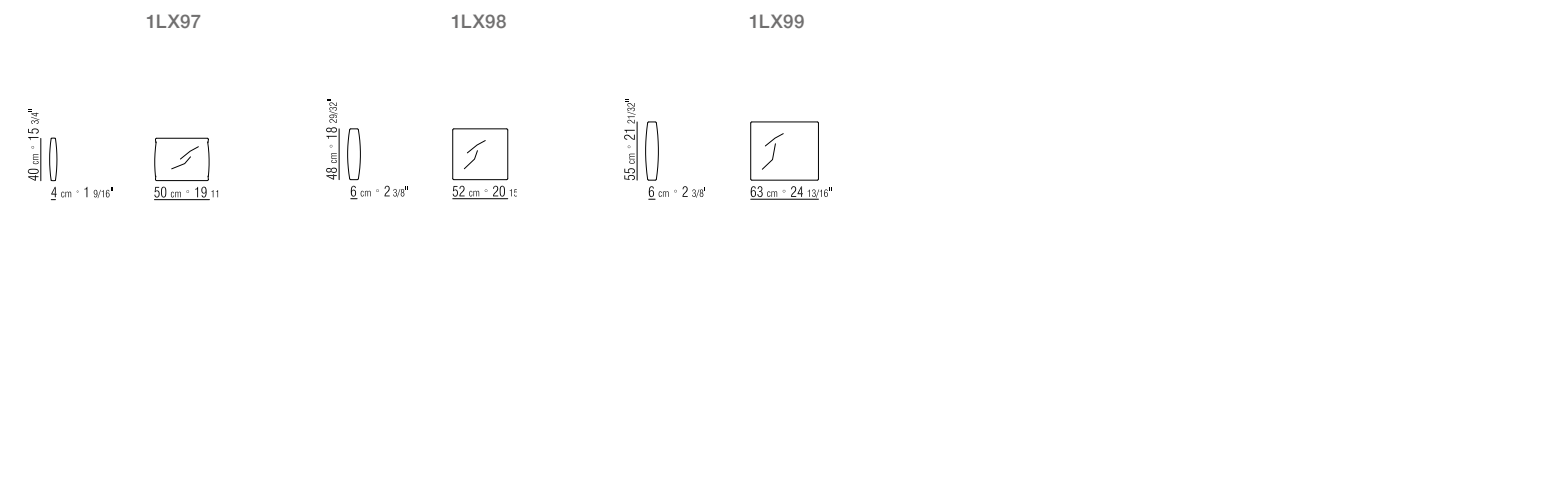
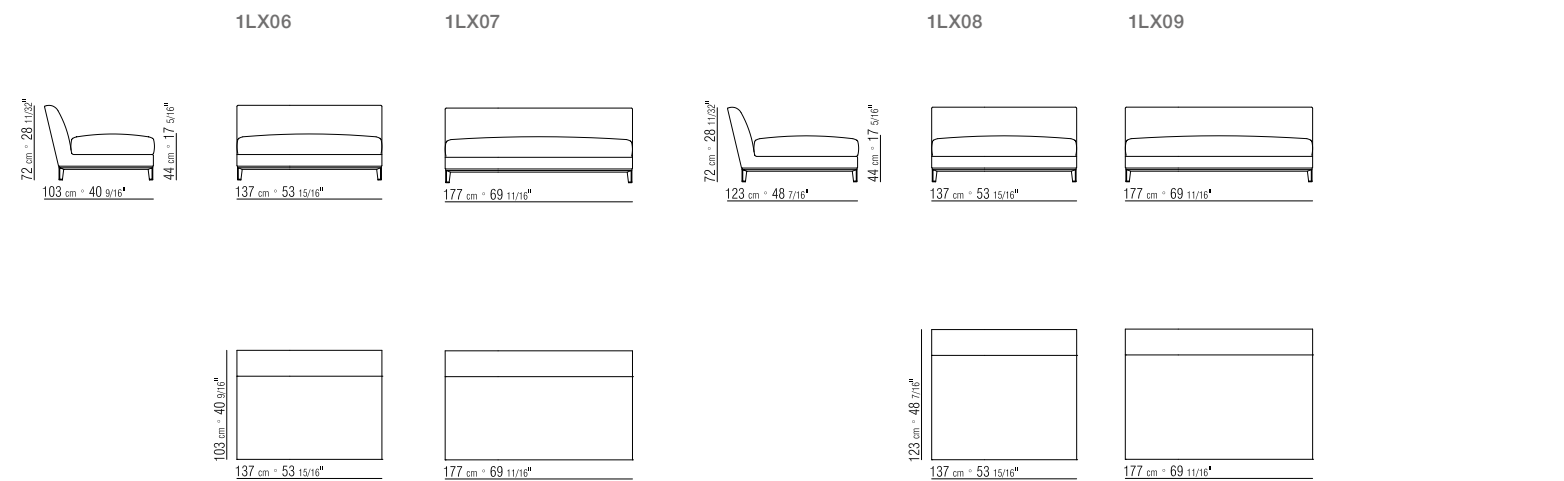
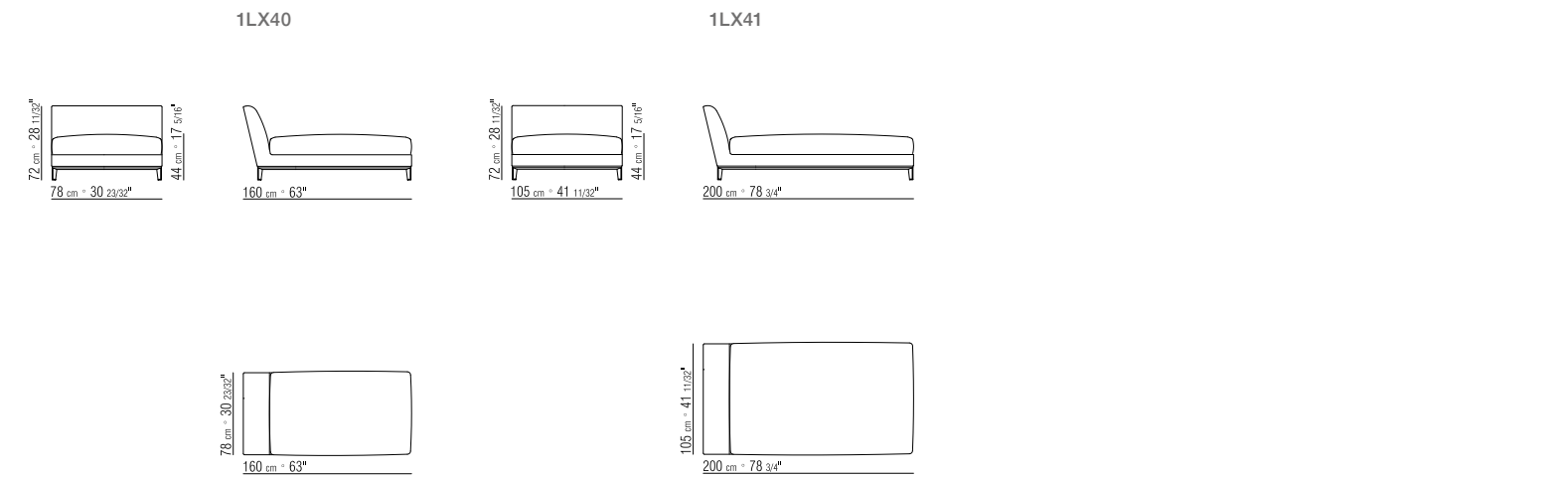
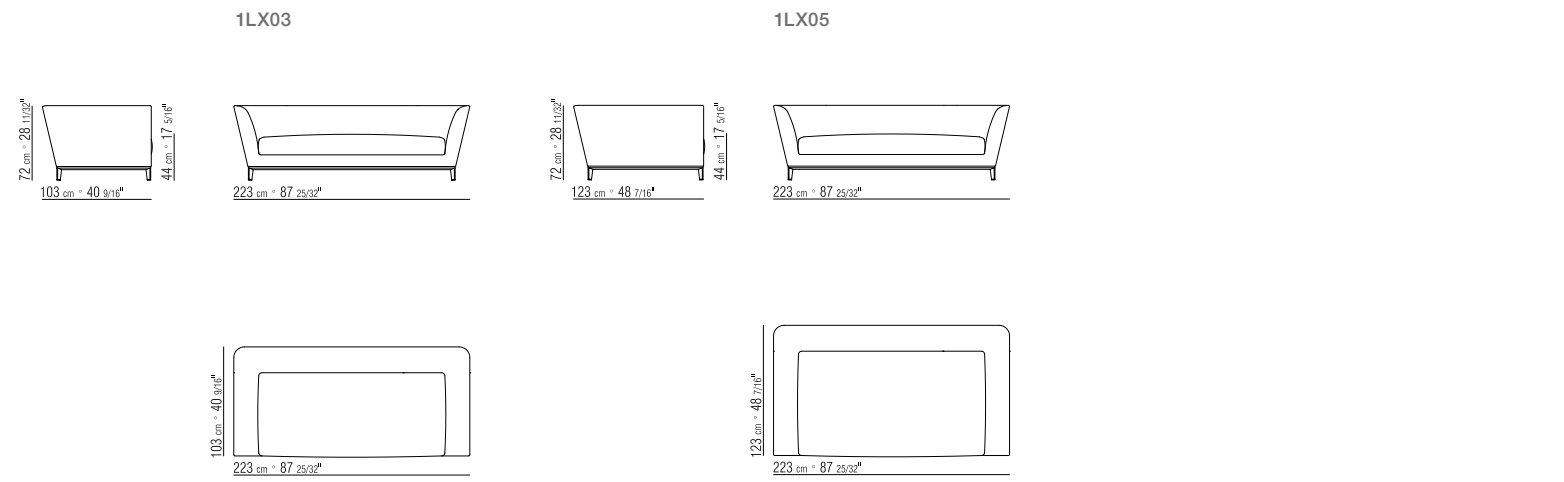

TIPOLOGIE DIVANI/DIVANI componibili/POUF - CHAISELONGUE/DORMEUSE
PRODOTTO DIVANO - DIVANO componibile - CHAISE LONGUE **STRUTTURA E SEDUTA** IN LEGNO MASSELLO CON IMBOTTITURA IN POLIURETANO ESPANSO A DENSITÀ DIFFERENZIATA E DACRON RIVESTITI IN TESSUTO PROTETTIVO ACCOPPIATO
CUSCINI OPTIONAL IN PIUMA D'OCA STERILIZZATA (CERTIFICATA ASSOPIUMA, ETICHETTA ORO). A RICHIESTA CON SUPPLEMENTO DI PREZZO **BASE** IN METALLO NELLE FINITURE CROMATO, CROMO NERO, SATINATO, BRUNITO, CHAMPAGNE **PIEDI** IN ALLUMINIO PRESSOFUSO NELLE FINITURE CROMATO, CROMO NERO, SATINATO, BRUNITO, CHAMPAGNE. APPOGGIO A TERRASU PUNTALE IN MATERIALE TERMOPLASTICO
RIVESTIMENTO SFODERABILE SIA NELLA VERSIONE IN TESSUTO CHE NELLA VERSIONE IN PELLE **PROFILO RIVESTIMENTO** LA CONFEZIONE PREVEDE UN PROFILO IN GROS GRAIN CHE PUÒ ESSERE REALIZZATO IN TUTTI I COLORI DELLA CARTELLA CAMPIONI

TYPES SOFAS/SECTIONAL SOFAS/OTTOMANS - CHAISE LONGUES/DAYBEDS
PRODUCT SOFA - SECTIONAL SOFA - OTTOMAN **STRUCTURE AND SEAT** IN SOLID WOOD WITH PADDING IN VARIABLE-DENSITY POLYURETHANE FOAM AND DACRON, COVERED WITH PROTECTIVE LAMINATED FABRIC **OPTIONAL CUSHIONS** IN STERILIZED GOOSE DOWN (ASSOPIUMA CERTIFIED, GOLD LABEL). UPON REQUEST, WITH UPCHARGE **BASE** IN METAL WITH CHROME, BLACK CHROME, SATIN, BURNISHED OR CHAMPAGNE FINISH **FEET** IN CAST ALUMINUM WITH CHROME, BLACK CHROME, SATIN, BURNISHED OR CHAMPAGNE FINISH. **FEET REST ON TIPS** MADE OF THERMOPLASTIC MATERIAL **UPHOLSTERY** IS REMOVABLE IN BOTH THE FABRIC AND LEATHER VERSIONS **CHOOSE THE PIPING IN GROS GRAIN**, AVAILABLE IN ALL THE COLORS ON THE SAMPLE BOARD, FOR BOTH FABRIC AND LEATHER COVERS.





Roberto Lazzeroni ha curato il restyling di alcuni tra i prodotti più identificativi della collezione Mood che assumono una connotazione stilistica più definita ed un gusto decorativo sofisticato e contemporaneo. Oggetto dell'intervento di restyling è stata la base d'appoggio delle sedute che è stata visivamente alleggerita: poltrone e divanetti poggiano ora su eleganti piedini in alluminio pressofuso disponibili in una varietà di eleganti finiture, oltre che nella più tradizionale versione in legno.

Roberto Lazzeroni curated the restyling of some of the Mood collection's signature products, giving them a more well-defined style identity and a refined, contemporary vibe.

The restyling focused on a visual lightening of the base. The armchairs and settees now rest on cast aluminum feet available in a number of elegant finishes, as well as the more traditional wood version.



Dragonfly 20

Roberto Lazzeroni

La collezione Dragonfly 20 è composta da poltrone, divani e dormeuse che si prestano ad arredare con grazia e charme sia ambienti domestici sia spazi hospitality quali lobby, lounge, sale d'attesa e suite.

La poltrona Dragonfly 20 è caratterizzata da dimensioni compatte e si mantiene sollevata da terra attraverso eleganti piedini in alluminio pressofuso oppure in massello di frassino, ambedue disponibili in una varietà di raffinate finiture. Le linee aggraziate che contraddistinguono la poltrona ed il divanetto Dragonfly 20 sono rimarcate dal ricercato profilo in gros grain che rifinisce il rivestimento e sottolinea la consolidata maestria artigianale con la quale viene eseguita la confezione.

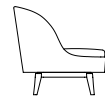

SOFAS
SECTIONAL SOFAS
ARMCHAIRS
OTTOMANS

The Dragonfly 20 collection comprises armchairs, sofas and daybeds, crafted to furnish both residential and hospitality spaces – like lobbies, lounges, waiting rooms and suites – with charm and elegance.

The Dragonfly 20 armchair features paired-down proportions and sits on elegant cast aluminum or solid wood feet. Both options come in an array of sophisticated finishes. The graceful lines that set the Dragonfly 20 armchair and settee apart are highlighted by refined grosgrain piping that lends a finely-finished touch to the upholstery and speaks to the time-tested artisan skill that goes into their making.











TIPOLOGIE DIVANI/DIVANI componibili/POUF - POLTRONE/POUF **PRODOTTO** DIVANO - POLTRONA **STRUTTURA** IN MATERIALE BREVETTATO RIVESTITO IN TESSUTO PROTETTIVO ACCOPPIATO **SEDUTA** IN POLIURETANO ESPANSO RIVESTITA IN TESSUTO PROTETTIVO ACCOPPIATO **BASE** IN METALLO VERNICIATO A FORNO CON POLVERI EPOSSIDICHE **PIEDI** IN LEGNO MASSELLO DI FRASSINO NELLE FINITURE NATURALE, TINTO EBANO, TINTO WENGÈ, TINTO MARRONE O IN ALLUMINIO PRESSOFUSO NELLE FINITURE SATINATO, CROMATO, CROMATO NERO, BRUNITO, CHAMPAGNE. APPOGGIO A TERRA SU PUNTALI IN MATERIALE TERMOPLASTICO **CUSCINI OPTIONAL** IN PIUMA D'OCA STERILIZZATA (CERTIFICATA ASSOPIUMA, ETICHETTA ORO). I CUSCINI OPTIONAL SONO A RICHIESTA CON SUPPLEMENTO DI PREZZO **RIVESTIMENTO** NON SFODERABILE SIA NELLA VERSIONE IN TESSUTO CHE NELLA VERSIONE IN PELLE **PROFILO RIVESTIMENTO** LA CONFEZIONE PREVEDE UN PROFILO IN GROS GRAIN CHE PUÒ ESSERE REALIZZATO IN TUTTI I COLORI DELLA CARTELLA CAMPIONI. PER RIVESTIMENTO IN PELLE IL PROFILO È REALIZZATO NELLA STESSA PELLE

TYPES SOFAS/SECTIONAL SOFAS/OTTOMANS - ARMCHAIRS/OTTOMMANS **PRODUCT** SOFA - ARMCHAIR **STRUCTURE** PADDED WITH PATENTED MATERIAL **SEAT** IN POLYURETHANE FOAM COVERED WITH A PROTECTIVE LAMINATED FABRIC **BASE** IN METAL WITH EPOXY POWDER-COAT FINISH **FEET** IN SOLID ASH WITH NATURAL FINISH; OR, STAINED EBONY, WENGE OR BROWN; OR, IN CAST ALUMINUM WITH SATIN, CHROME, BLACK CHROME, BURNISHED OR CHAMPAGNE FINISH. FEET REST ON TIPS MADE OF THERMOPLASTIC MATERIAL **OPTIONAL CUSHIONS** IN STERILIZED GOOSE DOWN (ASSOPIUMA CERTIFIED, GOLD LABEL). OPTIONAL CUSHIONS ARE UPON REQUEST, WITH UPCHARGE **UPHOLSTERY** IS NON-REMOVABLE IN BOTH THE FABRIC AND LEATHER VERSIONS **UPHOLSTERY PIPING** WITH FABRIC COVERS THE PIPING COMES IN GROS GRAIN, AVAILABLE IN ALL THE COLORS ON THE SAMPLE BOARD. WITH LEATHER COVERS THE PIPING COMES ALWAYS IN THE SAME LEATHER

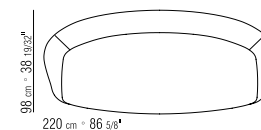
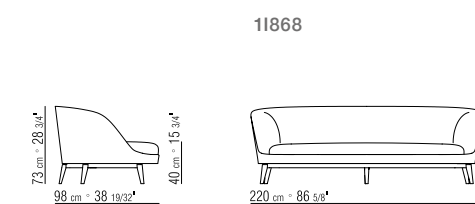
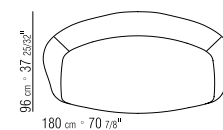
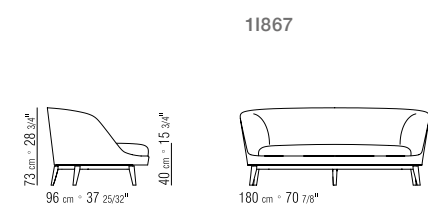
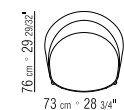
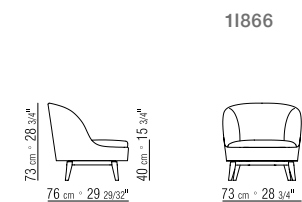

Drop 20

Roberto Lazzeroni

Divano e poltrona, le sedute Drop 20 sono contraddistinte da linee aggraziate e da proporzioni contenute che consentono loro di arredare con stile ed eleganza sia ambienti domestici che spazi hospitality.

Il divano Drop 20 presenta un'originale forma a fagiolo e poggia su eleganti piedini in alluminio pressofuso oppure in massello di frassino, ambedue disponibili in una varietà di raffinate finiture. Lo schienale dalla forma avvolgente e dall'imbottitura generosa consente un appoggio particolarmente confortevole. Il rivestimento, in pelle o tessuto, unito alla varietà di finiture della base accentua la versatilità del divano Drop 20.



SOFAS
SECTIONAL SOFAS
ARMCHAIRS
OTTOMANS

Both a sofa and an armchair, their graceful lines and restrained proportions make Drop 20 the ideal choice for furnishing homes and hospitality spaces with style and elegance.

The kidney-bean shape of the Drop 20 sofa is singularly appealing. The sofa rests on elegant cast aluminum or solid ash feet. Both options come in an array of elegant finishes. The enveloping, generously padded backrest offers especially comfortable support. Whether upholstered in leather or fabric, enhanced by a variety of finishes available for the base, the Drop 20 is a very versatile sofa.











TIPOLOGIE DIVANI/DIVANI COMPONENTI/POUF - POLTRONE/POUF **PRODOTTO** DIVANO - POLTRONA **SCHIENALE** IN METALLO CON IMBOTTITURA IN POLIURETANO ESPANSO RIVESTITA IN TESSUTO PROTETTIVO ACCOPPIATO **SEDUTA** IN LEGNO MULTISTRATO CON IMBOTTITURA IN POLIURETANO ESPANSO A DENSITÀ DIFFERENZIATA RIVESTITO IN TESSUTO PROTETTIVO ACCOPPIATO **BASE** IN METALLO VERNICIATO A FORNO CON POLVERI EPOSSIDICHE **PIEDI** IN LEGNO MASSELLO DI FRASSINO NELLE FINITURE NATURALE, TINTO EBANO, TINTO WENGÈ, TINTO MARRONE O IN ALLUMINIO PRESSOFUSO NELLE FINITURE SATINATO, CROMATO, CROMATO NERO, BRUNITO, CHAMPAGNE. APPOGGIO A TERRA SU PUNTALI IN MATERIALE TERMOPLASTICO **RIVESTIMENTO** NON SFODERABILE SIA NELLA VERSIONE IN TESSUTO CHE NELLA VERSIONE IN PELLE **PROFILO RIVESTIMENTO** LA CONFEZIONE PREVEDE UN PROFILO IN GROS GRAIN CHE PUO' ESSERE REALIZZATO IN TUTTI I COLORI DELLA CARTELLA CAMPIONI. PER RIVESTIMENTO IN PELLE IL PROFILO È REALIZZATO NELLA STESSA PELLE

TYPES SOFAS/SECTIONAL SOFAS/OTTOMANS - ARMCHAIRS/OTTOMANS **PRODUCT** SOFA - ARMCHAIR **BACKREST** BACKREST IN METAL WITH POLYURETHANE FOAM PADDING, COVERED WITH A PROTECTIVE LAMINATED FABRIC **SEAT** IN PLYWOOD WITH PADDING IN VARIABLE-DENSITY POLYURETHANE FOAM, COVERED WITH A PROTECTIVE LAMINATED FABRIC **BASE** IN METAL WITH EPOXY POWDER-COAT FINISH **FEET** IN SOLID ASH WITH NATURAL FINISH; OR, STAINED EBONY, WENGE OR BROWN; OR, IN CAST ALUMINUM WITH SATIN, CHROME, BLACK CHROME, BURNISHED OR CHAMPAGNE FINISH. FEET REST ON TIPS MADE OF THERMOPLASTIC MATERIAL **UPHOLSTERY** IS NON-REMOVABLE IN BOTH THE FABRIC AND LEATHER VERSIONS **UPHOLSTERY PIPING** WITH FABRIC COVERS THE PIPING COMES IN GROS GRAIN, AVAILABLE IN ALL THE COLORS ON THE SAMPLE BOARD. WITH LEATHER COVERS THE PIPING COMES ALWAYS IN THE SAME LEATHER

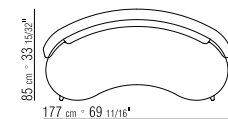
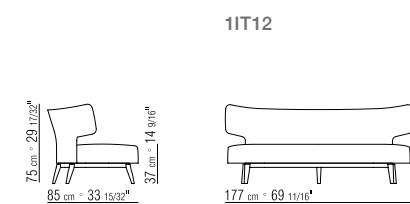
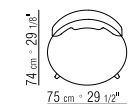
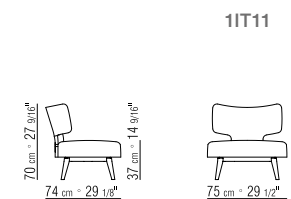

Un nome attinto dalla mitologia per sottolineare l'aspetto aggraziato e gentile della poltrona Ermione 20. Contenuta nelle proporzioni, la poltrona Ermione 20 è un passe-partout che può inserirsi con charme in qualsiasi ambiente. È caratterizzata da uno schienale imbottito dalla forma avvolgente alleggerito da una parte aperta in prossimità della seduta. Le linee garbate e l'allure vagamente retrò che contraddistinguono la poltrona Ermione 20 sono enfatizzate dalla base di appoggio costituita da eleganti piedini in alluminio pressofuso oppure in massello di frassino, ambedue disponibili in una varietà di raffinate finiture.



SOFAS
SECTIONAL SOFAS
ARMCHAIRS
OTTOMANS

Its mythology-inspired name serves to underscore the delicately graceful lines of the Ermione 20 armchair. Understated proportions add to the Ermione 20's versatility. With a charisma all its own, this is an armchair that can effortlessly enhance the decor in any setting. The exquisitely sculpted opening above the seat lightens the appearance of the enveloping upholstered backrest. The graceful lines and vaguely retro charm of the Ermione 20 armchair are also reflected in its base, made of cast aluminum or solid ash, both available in an array of finishes.











TIPOLOGIE DIVANI/DIVANI componibili/POUF - POLTRONE/POUF **PRODOTTO** DIVANO - POLTRONA **SCHIENALE** IN METALLO CON IMBOTTITURA IN POLIURETANO STAMPATO RIVESTITO IN TESSUTO PROTETTIVO ACCOPPIATO **SEDUTA** IN LEGNO MULTISTRATO CON IMBOTTITURA IN POLIURETANO ESPANSO RIVESTITO IN TESSUTO PROTETTIVO ACCOPPIATO **BASE** IN METALLO VERNICIATO A FORNO CON POLVERI EPOSSIDICHE **PIEDI** IN LEGNO MASSELLO DI FRASSINO NELLE FINITURE NATURALE, TINTO EBANO, TINTO WENGÈ, TINTO MARRONE O IN ALLUMINIO PRESSOFUSO NELLE FINITURE SATINATO, CROMATO, CROMATO NERO, BRUNITO, CHAMPAGNE. APPOGGIO A TERRA SU PUNTALI IN MATERIALE TERMOPLASTICO **RIVESTIMENTO** NON SFODERABILE SIA NELLA VERSIONE IN TESSUTO CHE NELLA VERSIONE IN PELLE **PROFILO RIVESTIMENTO** LA CONFEZIONE PREVEDE UN PROFILO IN GROS GRAIN CHE PUÒ ESSERE REALIZZATO IN TUTTI I COLORI DELLA CARTELLA CAMPIONI. PER RIVESTIMENTO IN PELLE IL PROFILO È REALIZZATO NELLA STESSA PELLE

TYPES SOFAS/SECTIONAL SOFAS/OTTOMANS - ARMCHAIRS/OTTOMANS **PRODUCT** SOFA - ARMCHAIR **BACKREST** IN METAL WITH MOLDED POLYURETHANE PADDING, COVERED WITH A PROTECTIVE LAMINATED FABRIC **SEAT** IN PLYWOOD WITH POLYURETHANE FOAM PADDING, COVERED WITH A PROTECTIVE LAMINATED FABRIC **BASE** IN METAL WITH EPOXY POWDER-COAT FINISH **FEET** IN SOLID ASH WITH NATURAL FINISH OR STAINED EBONY, WENGE OR BROWN; OR, IN CAST ALUMINUM WITH SATIN, CHROME, BLACK CHROME, BURNISHED OR CHAMPAGNE FINISH. FEET REST ON TIPS MADE OF THERMOPLASTIC MATERIAL **UPHOLSTERY** IS NON-REMOVABLE IN BOTH THE FABRIC AND LEATHER VERSIONS **UPHOLSTERY PIPING** WITH FABRIC COVERS THE PIPING COMES IN GROS GRAIN, AVAILABLE IN ALL THE COLORS ON THE SAMPLE BOARD. WITH LEATHER COVERS THE PIPING COMES ALWAYS IN THE SAME LEATHER

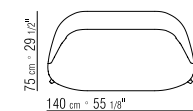
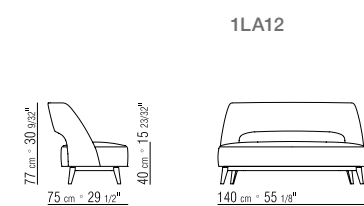
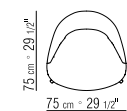
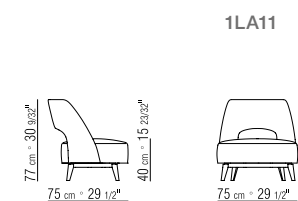

Lysandre 20

Roberto Lazzeroni

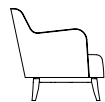

SOFAS
SECTIONAL SOFAS
ARMCHAIRS
OTTOMANS

La poltrona ed il divanetto Lysandre 20 sono assolutamente riconducibili alla tradizione del salotto borghese connotato da uno stile garbato e fatto di pezzi dall'appeal al di là del tempo e delle mode. Proporzioni compatte e un'estetica morbida e "curvy" sottolineata dal ricercato profilo in gros grain conferiscono alle sedute Lysandre 20 un tono sofisticato. La base di appoggio è costituita da eleganti piedini in alluminio pressofuso oppure in massello di frassino, ambedue disponibili in una varietà di raffinate finiture.

The graceful lines of the Lysandre 20 armchair and settee call to mind the traditional drawing room filled with timeless pieces that transcend the bounds of time and fashion. Scaled-down proportions and soft, curvy lines emphasized by sophisticated grosgrain piping, lend the Lysandre 20 seating elements a definite air of elegance. The base and feet, made of refined cast aluminum or solid ash, are available in an array of sophisticated finishes.







72



73





TIPOLOGIE DIVANI/DIVANI componibili/POUF - POLTRONE/POUF **PRODOTTO** DIVANO - POLTRONA **STRUTTURA** IN METALLO CON IMBOTTITURA IN POLIURETANO STAMPATO RIVESTITO IN TESSUTO PROTETTIVO ACCOPPIATO **SEDUTA** IN LEGNO MULTISTRATO CON IMBOTTITURA IN POLIURETANO ESPANSO A DENSITÀ DIFFERENZIATA RIVESTITO IN TESSUTO PROTETTIVO ACCOPPIATO **BASE** IN METALLO VERNICIATO A FORNO CON POLVERI EPOSSIDICHE **PIEDI** IN LEGNO MASSELLO DI FRASSINO NELLE FINITURE NATURALE, TINTO EBANO, TINTO WENGÈ, TINTO MARRONE O IN ALLUMINIO PRESSOFUSO NELLE FINITURE SATINATO, CROMATO, CROMATO NERO, BRUNITO, CHAMPAGNE. APPOGGIO A TERRA SU PUNTALI IN MATERIALE TERMOPLASTICO **RIVESTIMENTO** NON SFODERABILE SIA NELLA VERSIONE IN TESSUTO CHE NELLA VERSIONE IN PELLE **PROFILO RIVESTIMENTO** LA CONFEZIONE PREVEDE UN PROFILO IN GROS GRAIN CHE PUÒ ESSERE REALIZZATO IN TUTTI I COLORI DELLA CARTELLA CAMPIONI. PER RIVESTIMENTO IN PELLE IL PROFILO È REALIZZATO NELLA STESSA PELLE

TYPES SOFAS/SECTIONAL SOFAS/OTTOMANS - ARMCHAIRS/OTTOMANS **PRODUCT** SOFA - ARMCHAIR **STRUCTURE** IN METAL WITH MOLDED POLYURETHANE PADDING, COVERED WITH A PROTECTIVE LAMINATED FABRIC **SEAT** IN PLYWOOD WITH PADDING IN VARIABLE-DENSITY POLYURETHANE FOAM, COVERED WITH A PROTECTIVE LAMINATED FABRIC **BASE** IN METAL WITH EPOXY POWDER-COAT FINISH **FEET** IN SOLID ASH WITH NATURAL FINISH; OR, STAINED EBONY, WENGE OR BROWN; OR, IN CAST ALUMINUM WITH SATIN, CHROME, BLACK CHROME, BURNISHED OR CHAMPAGNE FINISH. FEET REST ON TIPS MADE OF THERMOPLASTIC MATERIAL **UPHOLSTERY** IS NON-REMOVABLE IN BOTH THE FABRIC AND LEATHER VERSIONS **UPHOLSTERY PIPING** WITH FABRIC COVERS THE PIPING COMES IN GROS GRAIN, AVAILABLE IN ALL THE COLORS ON THE SAMPLE BOARD. WITH LEATHER COVERS THE PIPING COMES ALWAYS IN THE SAME LEATHER

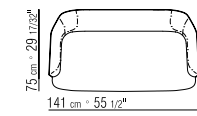
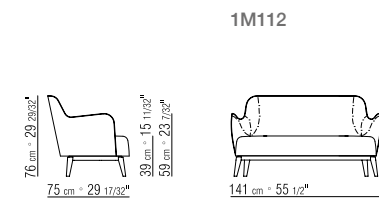
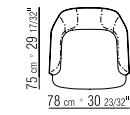
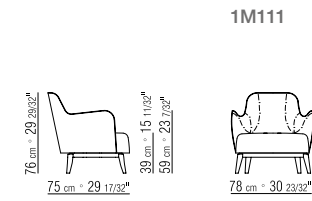



PRINTED IN ITALY
OCTOBER 2020

FLEXFORM S.P.A.
VIA EINAUDI 23/25
20821 MEDA (MB) ITALIA
TEL. +39 0362 3991
INFO@FLEXFORM.IT
WWW.FLEXFORM.IT



FLEXFORM SI RISERVA IL DIRITTO DI APPORTARE AI PROPRI MODELLI QUALSIASI MIGLIORAMENTO TECNICO ED ESTETICO DOVESSE ESSERE RITENUTO OPPORTUNO, COMPRESSE EVENTUALI MODIFICHE ALLE DIMENSIONI E AI MATERIALI UTILIZZATI, SENZA OBBLIGO DI PREAVVISO.

FLEXFORM RESERVES THE RIGHT TO MAKE ANY TECHNICAL AND AESTHETICAL IMPROVEMENTS, WHICH MIGHT BE CONSIDERED APPROPRIATE OR NECESSARY, INCLUDING CHANGES OF SIZES AND MATERIALS, WITHOUT ANY OBLIGATION OF PRIOR NOTICE.